

# Testing for Performance and Scalability: Using Ixia's Test Systems with the Avid Unity ISIS™ Real-Time Media Network



26601 W. Agoura Rd.  
Calabasas, CA 91302  
(Toll Free US) 1.877.FOR.IXIA  
(Int'l) +1.818.871.1800  
(Fax) 818.871.1805

[www.ixiacom.com](http://www.ixiacom.com)

Case Study



Copyright © 2006 by Ixia

All rights reserved

Ixia  
26601 West Agoura Road, Calabasas, CA 91302  
(877) FOR-IXIA

This Test Plan contains a general outline for testing a particular technology.  
Not all the capabilities of Ixia technology have been exposed in this document.  
Please feel free to contact us if additional capabilities are required.



# Avid Unity ISIS Case Study

---

## Contents

Introduction . . . . .	1
The Challenge . . . . .	2
The Solution . . . . .	3
Major Ixia Test System Features . . . . . and Benefits to Avid	4
Technical Background of the Avid Unity . . . . . ISIS Shared Storage System	5
Technical Background of Ixia's Test Systems . . . . .	6
Specific Ixia Test System Benefits . . . . .	8
Testing Scenarios . . . . .	9
Results . . . . .	10
Conclusion . . . . .	10

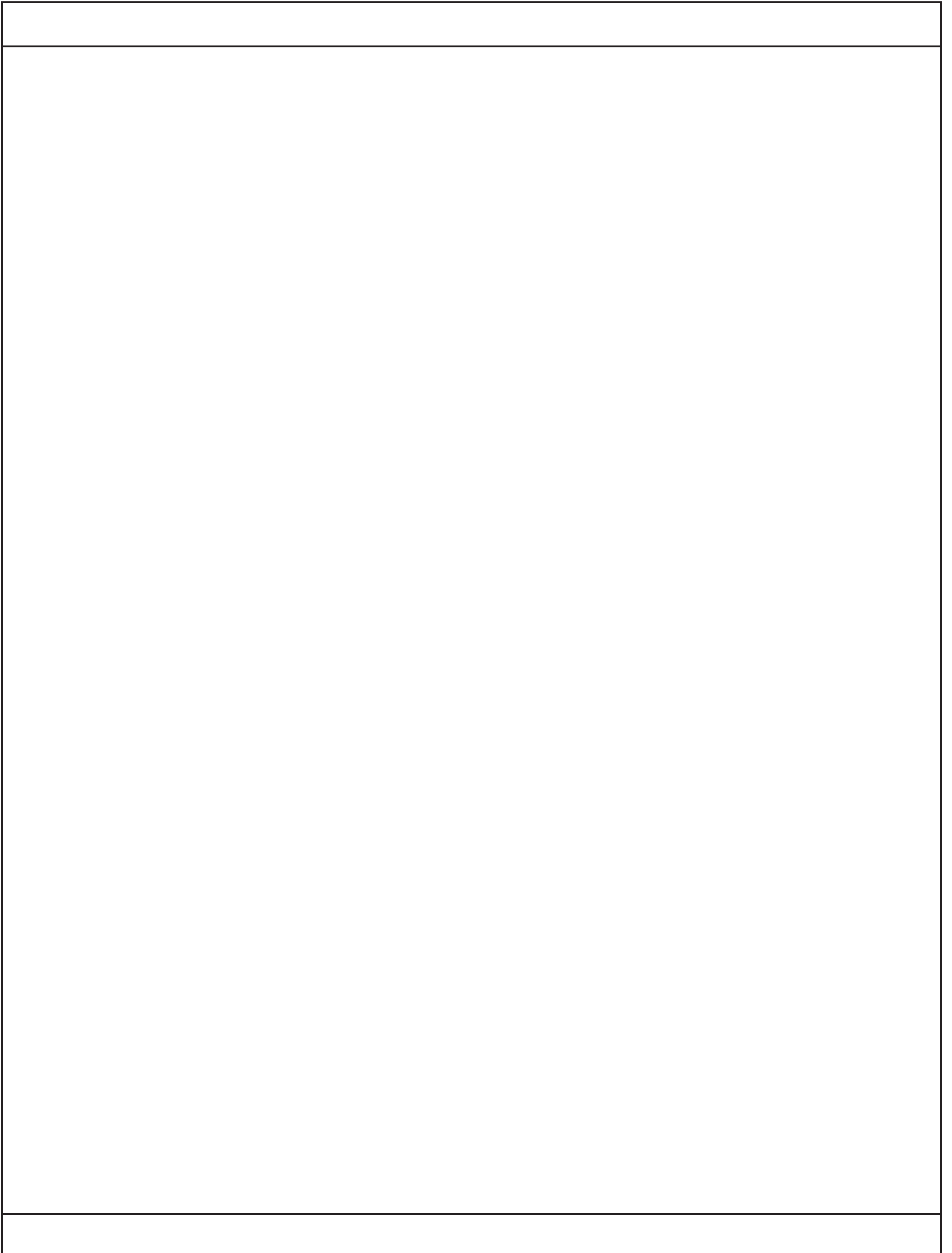



## Avid Unity ISIS Case Study

---

### Introduction

Avid Technology, Inc. is the world leader in digital media creation, management, and distribution solutions, enabling film, video, audio, animation, games, and broadcast professionals to work more efficiently, productively, and creatively. Key to the company's success is a deep history of product innovation and commitment to rigorous performance testing, ensuring that Avid® products meet and exceed user expectations.

Avid offers a wide range of real-time collaborative workgroup products in its Avid Unity™ family of shared media networks. The latest breakthrough is the Avid Unity ISIS (Infinitely Scalable Intelligent Storage) solution, which includes built-in standard Gigabit and 10 Gigabit Ethernet switching and offers an unprecedented combination of real-time performance, 24/7 availability, and massive scalability. To ensure that the Avid Unity ISIS switching technology meets the performance demands of its customers, Avid selected Ixia test systems for use during the Avid Unity ISIS qualification process.

As a leading provider of IP test systems, Ixia's Layer 2-7 test tools, featuring the Optixia® XL10 chassis, are capable of establishing large-scale performance and functionality testing of high-speed, high-capacity switches such as those in the Avid Unity ISIS system. Ixia's IxExplorer®, Aptixia IxLoad™, IxChariot®, and IxScriptMate™ automated test applications can generate wire-rate traffic from Layer 2-7 to automatically analyze thousands of traffic flows with comprehensive QoS and MOS metrics. Sophisticated configurations can be created using powerful wizards and grid controls that are part of Ixia's interactive Graphical User Interface (GUI) for managing Ixia test hardware and software resources.

### The Challenge

Prior to integrating the high port density GigE and 10GigE switching technology into the Avid Unity ISIS system, it was impossible to adequately stress test, or functionally challenge the system with a Windows- or Mac-based client test. Avid needed to be able to test every port of the Avid ISIS™ product at full duplex line rate speeds, which required purpose-built testing hardware, such as the Ixia line of chassis and interface load modules.

Another important requirement was to be able to build data flows that mimicked the real-world application of the Avid Unity ISIS system. Ixia was the perfect match for this requirement because of its targeted software test applications, such as IxLoad and IxChariot, which are capable of emulating full stateful traffic at very high volume.

Add to these significant technical challenges the need to pass the RFC 2544 and 2889 suite of tests and the fact that this was Avid's first storage solution designed solely on Ethernet, and it was obvious that the selection of the right test bed was crucial. Ixia's leadership position in the Ethernet testing market, offering a highly flexible and powerfully scalable test system, made Ixia a solid choice.

## **The Solution**

All Ixia test systems run on fully compatible, purpose-built hardware platforms, with interchangeable interfaces, utilizing a wide range test applications and Application Programming Interfaces (APIs). This creates a testbed that is fully integrated, which significantly increases productivity while reducing training requirements.

The specific Ixia test system configuration used by Avid featured the Optixia XL10, providing extreme high-port density for Gigabit Ethernet, along with the IXIA 1600T with 10 Gigabit Ethernet interfaces, and the IXIA 400T to provide test bed portability. A variety of Ixia test applications were used, such as IxLoad for comprehensive Layer 4-7 stateful traffic generation and performance assessment, IxChariot to predict device and system performance under realistic load conditions, including VoIP quality assessment. Ixia's IxScriptMate was used to automate the test bed and provide custom test scripts to meet Avid's stringent requirements. In addition, Ixia's flagship IxExplorer provided Layer 2-3 traffic loading and overall management of the test environment.

## Major Ixia Test System Features and Benefits to Avid

<i>Ixia Feature</i>	<i>Benefit to Avid</i>
<b>Latency/sequence checking views in wide packet group mode support 2 million (10GE LSM) receive flows.</b>	Offers the industry's highest flexibility for identifying individual packet flows, allowing Avid to test throughput, latency, and sequencing simultaneously across all of their traffic types.
<b>10GE Load Modules support 350MB capture memory per port.</b>	At 10Gb data rates, a large capture buffer is essential to capturing any meaningful results.
<b>Port Density – 54 ports of 10GE per Optixia XL10 chassis.</b>	Increased ease of management, maximizes rack real estate, and reduces chassis to chassis sync cabling.
<b>Detailed data plane testing. Ixia's L2-3 applications (IxExplorer and IxScriptMate) provide remarkable flexibility for meeting specific testing requirements.</b>	Both applications can be combined or used individually to accomplish large scale port testing. While testing in an automated fashion with IxScriptMate, IxExplorer's powerful data capturing and statistical analysis capabilities can be used for additional result interrogation.
<b>CPU per port architecture enables testing resources to be allocated down to a per port level.</b>	The nature of Avid's business includes different media types, including video. Ixia's CPU per port architecture offers the industry's highest performance with linear scalability when running high port count tests at higher layers, such as streaming video, voice, or enterprise network data.

## **Technical Background of the Avid Unity ISIS Shared Storage System**

The Avid Unity ISIS media network is a highly scalable, self-balancing distributed architecture that combines the Avid Unity ISIS 64-bit file system with the intelligent Avid ISIS Engine. Together, they offer support for up to 150 real-time 50Mb clients with simultaneous access to as much as 192 terabytes of storage and expandability planned for the future. Running on standard Gigabit Ethernet technology, the Avid Unity ISIS systems provide facility-wide uninterrupted access to media, powerful yet simple management tools, and an open architecture that supports both Avid and non-Avid clients in a range of mission-critical environments.

The Avid ISIS Engine is a unique blade-based storage subsystem that features intelligent dual-drive storage blades, integrated Ethernet switching, and redundant power and cooling. Each Avid ISIS Storage Blade is a mini-server including disks, processor, memory, and networking. For more information about the Avid Unity ISIS system, please go to <http://www.avid.com/unityISIS>.

## **Technical Background of Ixia's Test Systems**

The specific Ixia hardware test system configuration selected by Avid for its comprehensive testing requirements included the Optixia XL10, IXIA 1600T, and IXIA 400T Chassis. The Optixia X10 was especially important in this test because it offers the highest density test platform in the industry with up to 240 10/100/1000 Mbps Ethernet or 54 ports of 10 Gigabit Ethernet in a single chassis, capable of Layer 2-7 traffic generation and analysis at line rate. A number of Ixia software test applications were used to generate both Layer 2-3 and Layer 4-7 traffic:

- **IxExplorer®** – Powerful and interactive Graphical User Interface (GUI) for managing Ixia test hardware and executing Layer 2-3 testing.
- **Aptixia IxLoad™** – Comprehensive Layer 4-7 performance testing of content aware devices and networks.
- **IxChariot®** – Device and system performance testing under realistic load conditions for true Layer 4-7 testing, including VoIP.
- **IxScriptMate™** – Automated and custom scripting for performance, scalability, and functional testing of network devices.

### **IxExplorer®**

IxExplorer offers complete control for generation and analysis of Layer 2-3 traffic streams on an array of network interface technologies, including Ethernet, 10 Gigabit Ethernet, Packet over SONET (POS), ATM, Frame Relay, HDLC, etc. Ixia test ports can be independently configured to define traffic, filtering, and capture capabilities. Comprehensive statistics and graphical views enable in-depth analysis of the performance and functionality of the Device Under Test (DUT). IxExplorer also provides the GUI framework for executing IP routing protocol emulations within its Protocol Window.

## **Aptixia IxLoad™**

IxLoad is a highly scalable, integrated test solution for assessing the performance of Triple Play networks and devices. IxLoad emulates IPTV and Triple Play subscribers and associated protocols to ensure subscriber quality of experience (QoE). Protocols supported include video protocols like MPEG, IGMP, and RTSP; voice protocols like SIP and MGCP; and data protocols like HTTP, FTP, and SMTP. In addition, IxLoad can be used to test critical aspects of the infrastructure like DNS, DHCP, and AAA services, as well generate malicious traffic to test for security.

IxLoad is part of Ixia's Aptixia™ family of test applications and operates in conjunction with Optixia® – Ixia's industry-leading hardware platform.

## **IxChariot®**

IxChariot is the industry's leading Layer 4-7 traffic pattern analysis and decision support tool, emulating real-world application data, including email, database, CRM, P2P, online gaming, Voice over IP (VoIP) and Video over IP, without the need to install and maintain extensive client/server networks. IxChariot offers the ability to create sophisticated traffic patterns with and without QoS to measure throughput, jitter, packet loss, MOS (Mean Opinion Scores) for VoIP, and MDI (Media Delivery Index) for video over IP. IxChariot also has the capability to measure the impact of new technologies such as IPv6 and multicast video to assess the readiness of planned network changes.

The IxChariot Support Script Library includes support for over 100 IP service quality application tests, and also includes support for over 40 tests to troubleshoot connectivity, access, speed, email performance, etc. It can create sophisticated traffic patterns, and perform throughput, jitter, lost data, QoS and latency analysis using Performance Endpoints running directly from the customer's systems. It has the ability to troubleshoot critical performance issues to isolate deteriorating network segments and devices. Supported protocols include TCP, IPv4, IPv6, UDP, RTP, SPX, IPX and SNA, as well as IP Multicast.

### **IxScriptMate™**

The IxScriptMate application is a powerful, customizable test tool for automating the performance, scalability, and functional testing of network devices. IxScriptMate provides a simple-to-use Graphical User Interface to configure custom automated test scenarios and analyze test results. Utilizing the capabilities of Ixia test hardware, such as wire-speed traffic generation, filtering, capturing, and statistics collection, IxScriptMate provides a rich suite of pre-built tests based on industry standard RFCs and customer requirements.

### **Optixia XL10™**

High-end network switches and routers of today support hundreds of network ports generating terabits of data. With up to 240 ports of 10/100/1000 Mbps Ethernet or 54 ports of 10 Gigabit Ethernet in a single chassis, Ixia's Optixia® XL10 was created to efficiently meet the performance verification needs of such high density networking devices. All ports are capable of Layer 2-7 traffic generation and analysis at line rate. Optixia® XL10 is the highest density and highest performance test platform in the industry, providing development testing, system and performance testing, and manufacturing testing for devices ranging from switches and routers to content switches and web servers.

### **Specific Ixia Test System Benefits**

1. The IXIA Chassis, 10Gb Load Module, IxExplorer, IxChariot, IxLoad, and IxScriptMate are all mature products.
2. Avid has real-world testing experience because of the traffic volume and emulation capabilities of the Ixia hardware and software test systems.
3. Ixia supports a complete L2-7 test solution in a single platform without confusing overlap or compromise of functionality.
4. Ixia's hardware is compatible with all Ixia software modules, protecting Avid's investment and enabling seamless migration.
5. The Ixia platform continues to operate with hardware and software compatibility over 7 years after introduction.

## Testing Scenarios

Because the Avid Unity ISIS media network was a completely new design from Avid, the test configuration had an important overall objective, namely, to verify the system design prior to deployment in a production environment. Given the extreme capabilities of the Avid Unity ISIS media network (e.g., very high client count and infinite storage scalability), the test bed needed to be able to thoroughly test its capacity limits and performance characteristics by offering real-time, real-world traffic conditions. Numerous test iterations were run, changing the port count, as well as how the traffic flowed throughout the Avid Unity ISIS system, to emulate diverse user behavior. Several overnight tests were completed successfully, offering a large quantity of test data for analysis.

The comprehensive Ixia test bed illustrated here made it possible to execute RFC2544 tests for bi-directional throughput measurement on all test ports simultaneously (184 GigE ports and 7 10GigE ports). RFC2889 tests were performed focusing on mesh testing, with several fully meshed tests among all the GigE ports, as well as some partially meshed tests that included the 10GigE ports. Once these test results were gathered, a variety of latency tests were scripted to create flows that would maximize the throughput of the ISIS system, identifying where/when traffic thresholds were reached. The total port count for the testing was 7 10GigE ports and 207 GigE ports.

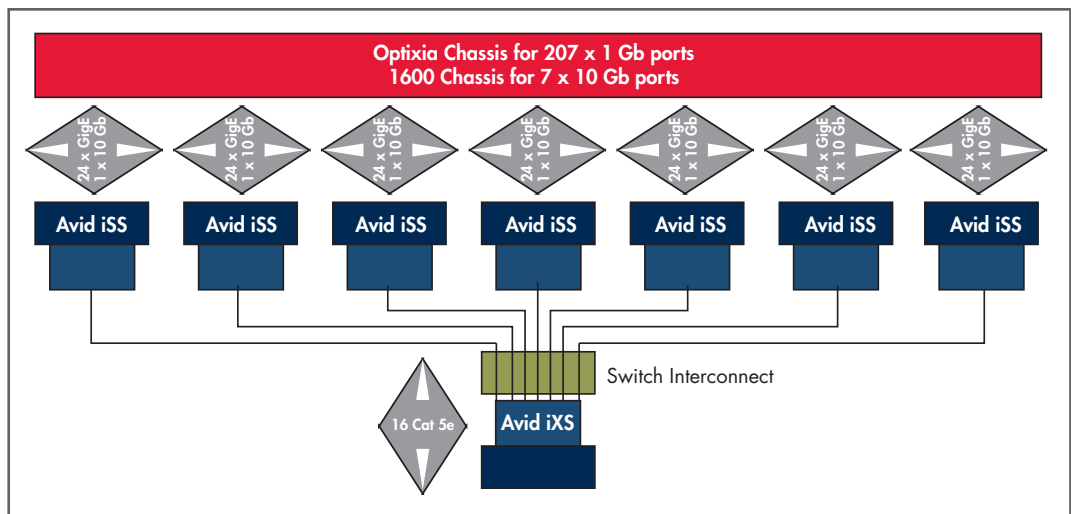

### Results

When the testing was in the planning stages, Avid expected test results to demonstrate that the Avid Unity ISIS media network was capable of line rate, full duplex performance throughout the stack, which was in fact verified by the Ixia test system during the actual testing. Since the Avid Unity ISIS buffering strategies are based on oversubscription, identifying buffering limits and producing specific result metrics was an especially useful test metric. Client scalability was another important metric that could only be accurately measured by subjecting the Avid Unity ISIS system to extremely high traffic loading conditions made possible with the Ixia test configuration.

Using IxScriptMate to create custom scripts that effectively simulated the Avid Unity ISIS application in production use did shed light on some power issues that were easily addressed in design reviews. Indeed, the flexibility of the Ixia test applications (e.g., IxLoad and IxChariot) made it possible for Avid to design traffic flows that accurately emulated a deployed Avid Unity ISIS network.

### Conclusion

The rigorous test methodology and comprehensive Ixia test configurations provided a wide range of test results that Avid can rely on to speed their time-to-market cycle and ensure product reliability. Additionally, the Ixia test bed that resides at Avid's development and QA facility provides a powerful, flexible, and portable test system that Avid uses daily to test new and emerging hardware/software designs, as well as to qualify third party switch designs that are part of the Layer 3 component of the Avid Unity ISIS media network.

*Avid, Avid ISIS, Avid Unity ISIS, and Avid Unity are either registered trademarks or trademarks of Avid Technology, Inc. or its subsidiaries in the United States and/or other countries.*

*Ixia, the Ixia four petal logo, Optixia, IxExplorer, Aptixia IxLoad, IxChariot, and IxScriptMate are registered trademarks or trademarks of Ixia. Other trademarks are the property of their respective owners.*